

A. J. PEAVEY & F. B. COTTON.

Devices for Holding and Carrying Pipe-Fittings Chucks.

No. 145,896.

Patented Dec. 23, 1873.

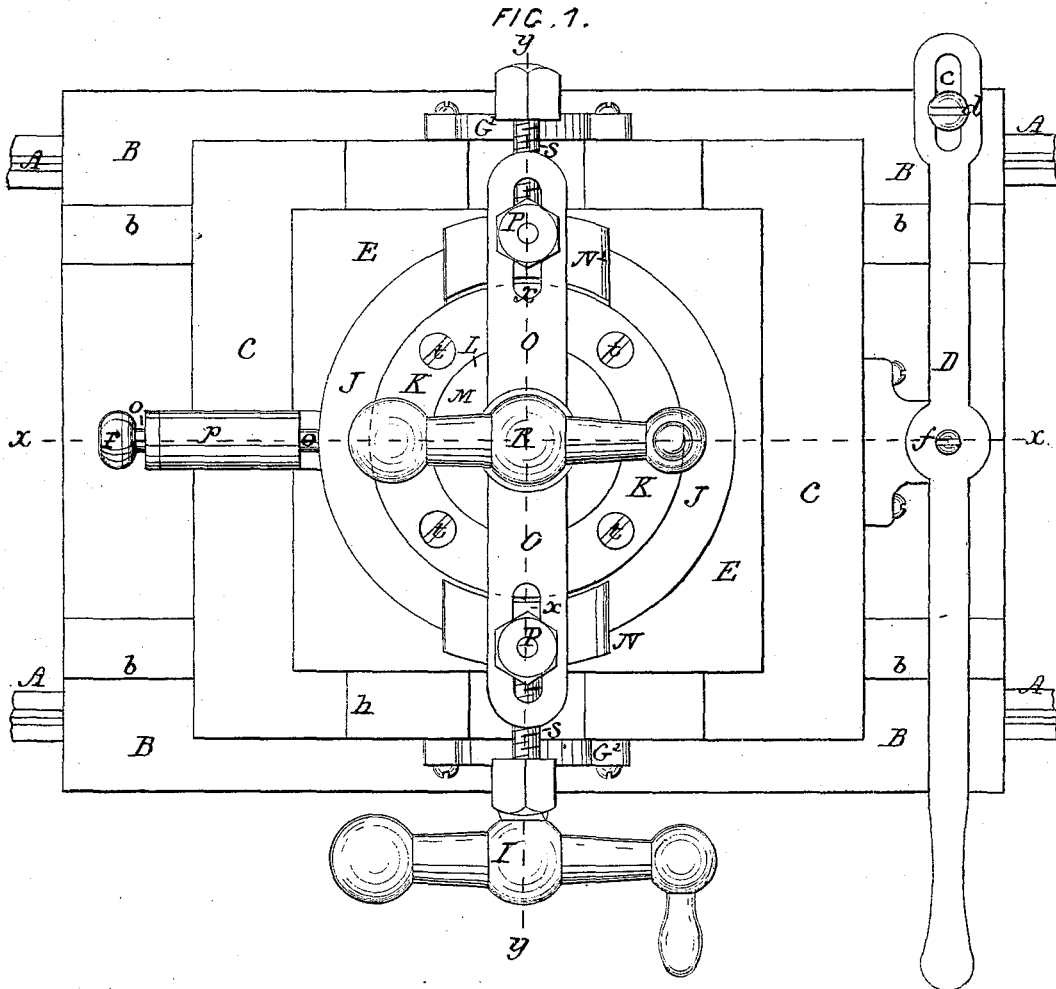

FIG. 4.

FIG. 5.

FIG. 6.

FIG. 7.

FIG. 8.

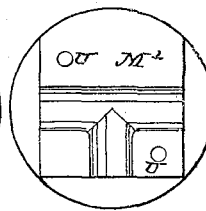
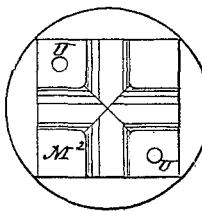
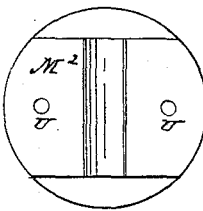
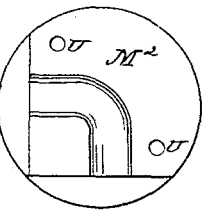
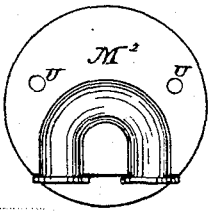

WITNESSES.

J. M. Chry
Robert Moxley

INVENTORS.

Andrew J. Peavey
and
Frank B. Cotton
per
Brown Brothers
Attorneys.

A. J. PEAVEY & F. B. COTTON.

Devices for Holding and Carrying Pipe-Fittings Chucks.

No. 145,896.

Patented Dec. 23, 1873.

FIG. 3.

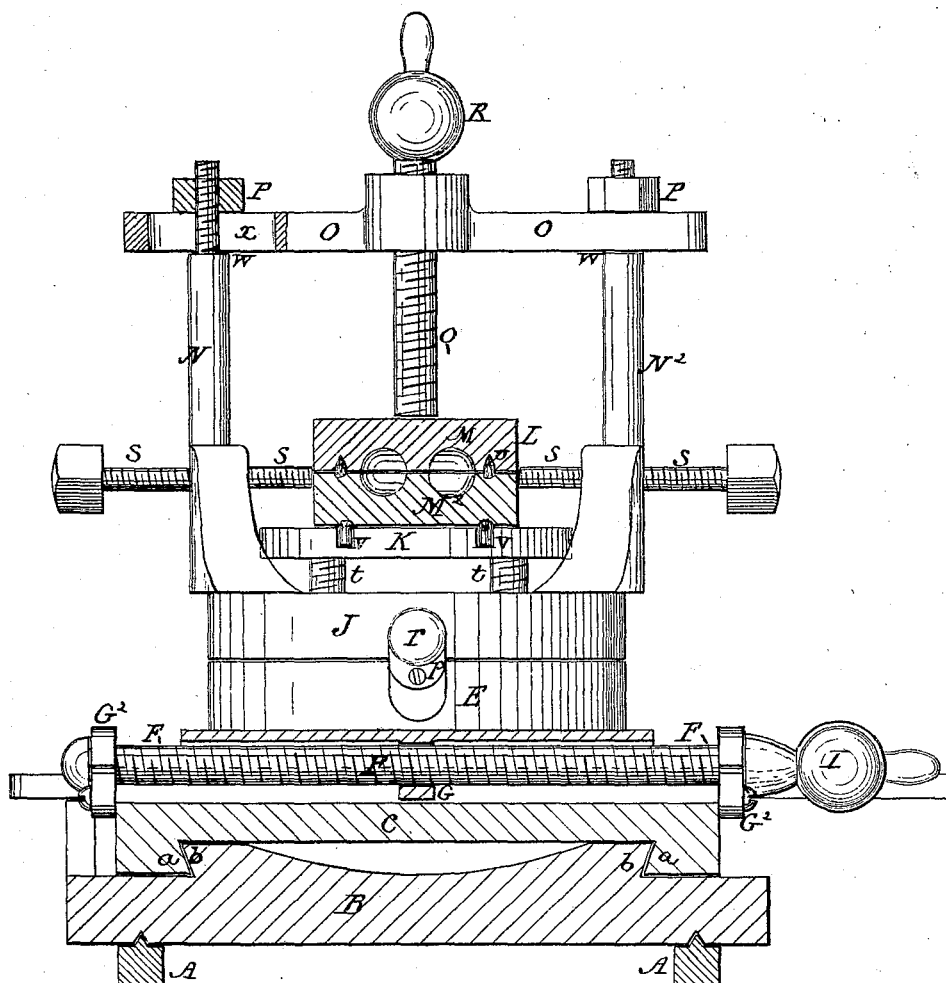

WITNESSES.
J. P. M. & Co. Eng.
Robert Morris

INVENTORS.
Andrew J. Peavey
and
Frank B. Cotton
per
Brown Brothers
Attorneys

UNITED STATES PATENT OFFICE.

ANDREW J. PEAVEY AND FRANK B. COTTON, OF BOSTON, MASSACHUSETTS;
SAID PEAVEY ASSIGNOR TO SAID COTTON.

IMPROVEMENT IN DEVICES FOR HOLDING AND CARRYING PIPE-FITTINGS CHUCKS.

Specification forming part of Letters Patent No. **145,896**, dated December 23, 1873; application filed April 22, 1873.

To all whom it may concern:

Be it known that we, ANDREW J. PEAVEY and FRANK B. COTTON, both of Boston, in the county of Suffolk and State of Massachusetts, have invented a certain new and useful Improvement in Devices for Holding and Carrying Pipe-Fittings Chucks; and that the following is a full, clear, and exact description of the same, reference being had to the accompanying plate of drawings.

This invention relates more particularly to the holder or carrier for chuck-blocks, the object being to adapt the chuck-block carrier or holder to bring the article held by the chuck-blocks into position to be operated upon by one tool after another, as, for instance, in the case of couplings, first by a reamer, and then a tap, thereby obviating the necessity of re-chucking the article, as is now the case. To this end the invention consists of a chuck carrier or holder constructed of a bed-plate, a platen operated by a lever, a second platen operated by a screw-rod, and a bed-piece having a pin or stop, all combined and arranged as hereinafter described, for imparting to the chuck-carrier a reciprocating, transverse, and rotating movement, in the manner and for the purpose hereinafter set forth.

In the accompanying plate of drawings, our improvements in lathe-chucks are illustrated.

In Plate 1, Figure 1 is a plan view of a lathe-chuck constructed and arranged according to this invention. In Plate 2, Fig. 2 is a side elevation with some parts along line *x x*, Fig. 1, Plate 1, in vertical section. In Plate 3, Fig. 3 is a partial elevation of another side of the lathe-chuck, with some parts along line *y y*, Fig. 1, Plate 1, in vertical section. In Plate 1, Figs. 4, 5, 6, 7, and 8 are face views in detail of chuck-blocks for holding couplings of the various shapes, as, for instance, respectively, "returns," "elbows," "straights," "cross-heads," and "T's."

A A in the drawings represent the usual parallel bed-rails of a lathe, on which, as ordinarily for tool-holders, is arranged a horizontal bed-plate, B, to be slid along their length, and to be fastened against accidental displacement. This bed-plate B carries the lathe-chuck embraced herein, and this chuck is con-

structed as follows: C, a horizontal platen, located on upper face of bed-plate B, and thereon confined from accidental detachment, while at the same time it is free to be slid in a direction corresponding to and parallel with the direction of the bed-rails A, by the interlock of its parallel guide-flanges *a* with the parallel guide-flanges *b* of the bed-plate B; D, a lever for operating the platen C. This lever is located in a horizontal plane transversely to the bed-rails, and at one end it is hung by a slot, *c*, to a vertical stud, *d*, of the bed-plate B. The other end of the lever D is adapted as a handle, and between the two ends the lever is hung to a vertical stud, *f*, of platen C; E, a platen, located on upper face of platen C, and thereon confined from accidental displacement, while at the same time it is free to be moved in a direction across the line of movement of the platen C by the interlock of its parallel guide-flanges *g* with the parallel guide-flanges *b* of the platen C; F, a screw-shaft for moving platen E on the platen C. This screw-shaft F is arranged horizontally midway between and parallel with the guide-flanges *g* of the platen E, and in its length it passes through a female screw-threaded opening, G, of the platen E, and loosely through fixed vertical ear-pieces G² of the platen C. The shaft E is confined against movement lengthwise in the ear-pieces G²; I, a handle to screw-shaft F, for convenience in turning it; J, a circular bed-piece on upper face to platen E. This circular bed-piece J is free to turn upon a vertical center post, *l*, of the platen E; but to the post *l* it is confined against detachment by the overlap of the washer *m* at the upper end of the post *l*; *n*, peripheral sockets of circular bed-piece J. These sockets *n* are radial with the center of the bed-piece J, and are four in number, one at each quarter division of the bed-piece periphery; *o*, a horizontal stem, arranged in a fixed horizontal casing, *p*, of the platen E. This stem is in position to interlock with the socket *n* of bed-piece J when one is brought into line with it by rotating the bed-piece J; *q*, a spiral spring in casing *p* for automatically interlocking stem *o* with the sockets *n*; and *r*, a head on stem for convenience in disengaging the stem from the sockets *n*;

K, a disk. This disk K rests upon shoulders *s* of four vertical screw-studs, *t*, of the circular bed-piece J, and each stud is at the corner of a square that is concentric with the center of bed-piece J. The screw-studs *t* are adapted to screw in and out of the bed-piece J, so that the upper face of the disk K can be adjusted to be parallel, or at an inclination with the horizontal level of the lathe-rail A; L, the chuck proper. In the present instance the chuck L is in two parts, M M², set together by dowel-pins *u*, and it is adapted for the reception of a return coupling, so known. The coupling is placed in and between the two parts M M², projecting, by its open ends, from one edge thereof. (See Fig. 4.) The chuck L is located concentrically upon the upper face of disk K, its concentricity being insured by dowel-pins *v*; N N², two vertical posts, of circular bed-piece J. These posts N N² are diametrically opposite to each other, and they are united at their upper ends by a horizontal cross-piece, O, which rests on a corresponding shoulder, *w*, of each post. This cross-piece O has a corresponding longitudinal slot, *x*, near each end, to allow it to be slid lengthwise over the posts, and then set against movement by screw-nuts P; Q, a vertical screw-shaft at center of cross-piece O, for confining chuck L in the direction of its thickness; R, a handle to screw-shaft Q, for convenience in turning it; S, screw-shafts, one to each post N N². These shafts S are in the same horizontal line, said line intersecting the lower part of chuck L.

In use, the chuck above described is placed, by its bed-piece B, upon the bed-rails A of a lathe, having a head-stock at each end, with each head-stock carrying a tool running in a horizontal plane, these tools being, in the present instance, the one a reamer and the other a tap. To chuck a coupling, as, for instance, a return, first select the proper chuck-blocks M M² and locate the coupling in them, as described, then place the chuck L upon the disk K and bring the side screws S and the upper screw Q to bear against it, which fastens the chuck to the disk K, and through it, to the bed-piece B. Before the chuck is secured to the disk K, as above stated, the disk is to be adjusted as to its height and inclination, to bring the bore of the coupling into the same horizontal plane as the tools. The chuck-coupling is now ready for presentation to the tools, first to the reamer and then to the tap. To move it toward and away from the tools, use the lever D. To set it over, so that both

ends of the coupling can be subjected to the tools, use the screw-shaft; and to bring the coupling into position for presentation to the tool at either end, revolve the bed-piece J; these several movements being, of course, made in the order requisite to secure the desired fitting of the coupling.

The bed-piece J is held from rotation, when set, by the spring-stem *o*. The location of the socket *n* is such that a coupling, whether it be a straight, an elbow, a return, a cross-head, or a T, can be brought into line for being fitted in all its openings.

For all couplings except an elbow the vertical screw Q is set at the central vertical axis of the chuck, but for an elbow it is set at the corner or bend of the elbow.

The rotation of the bed-piece J, obviously, may be subdivided other than herein described.

A chuck constructed substantially as herein described, and used upon a lathe having two or more tool-carrying head-stocks, obviously insures the utmost accuracy in the fitting of couplings, &c., and obviates the necessity of rechucking. It is obvious that a tool-carrying head-stock may be used at the rear side of the bed-rails.

Having thus described our invention, what we claim, and desire to secure by Letters Patent, is—

1. The bed-plate B, platen C, operated by lever D, platen E, operated by screw F, and bed-piece J having stop-pin O, each and all relatively constructed, combined, and arranged together for separate movement, substantially as and for the purpose described.

2. The bed-piece J, having the shouldered vertical screw-studs *t*, arranged as described, in combination with the disk K on said screw-studs, all constructed and arranged to operate substantially as herein described, for the purpose specified.

3. The vertical standards N N, attached to the bed-plate J, and carrying the set-screw S S, in combination with each other and with the cross-piece O and screw Q, all constructed and arranged to operate substantially as described.

The above specification of our invention signed by us this 9th day of April, A. D. 1873.

A. J. PEAVEY,
FRANK B. COTTON.

Witnesses:

ALBERT W. BROWN,
J. P. McELROY.